

record GATES

Roller shutters, rolling grilles and rapid shutter doors



record GATES

record GATES – Roller shutters, rolling grilles and rapid shutter doors

Welcome to record, your international partner for automatic door systems.

record delivers full and comprehensive know-how in the construction of automatic door systems and gates, all from the same provider. This ranges from the development and production of various mechanical and electronic components, the installation of entire door systems, to the full range of repair and maintenance services. We have subsidiaries in 17 countries, and more than 200 distributors all over the world to meet our customers' needs, and install around 75,000 new door systems and drives of different types every year.

The record program provides a wide range of automatic doors and peripheral devices for every conceivable application. Core products are linear and radial automatic sliding doors, swing door drives, folding doors, revolving doors, burglar-proof doors, security doors for use in escape and rescue routes, and fire protection barriers. It also includes special products such as doors for hygienically demanding applications, airtight doors and one-way door systems.

record GATES has expanded its product portfolio to include a series of roller shutters, rapid shutter doors and rolling grilles.

ISEA France, our French subsidiary, specializes in doors for trade and industry.



FERMETURES INDUSTRIELLES
COMMERCIALES & RÉSIDENTIELLES

Since its inception in 1979, it now sells around 15,000 units every year, all developed and produced in-house.

By incorporating ISEA France into the record Group, we are now perfectly positioned to provide entrance solutions for virtually every industrial and retail need, all of which we make and produce ourselves. On the one hand, this enables you the customer to benefit from a new calculation basis, and on the other, you always receive planning, installation and maintenance concomitantly with the current state of your project, all from a single source.

Let us inspire you! Your record partner is expecting your call.

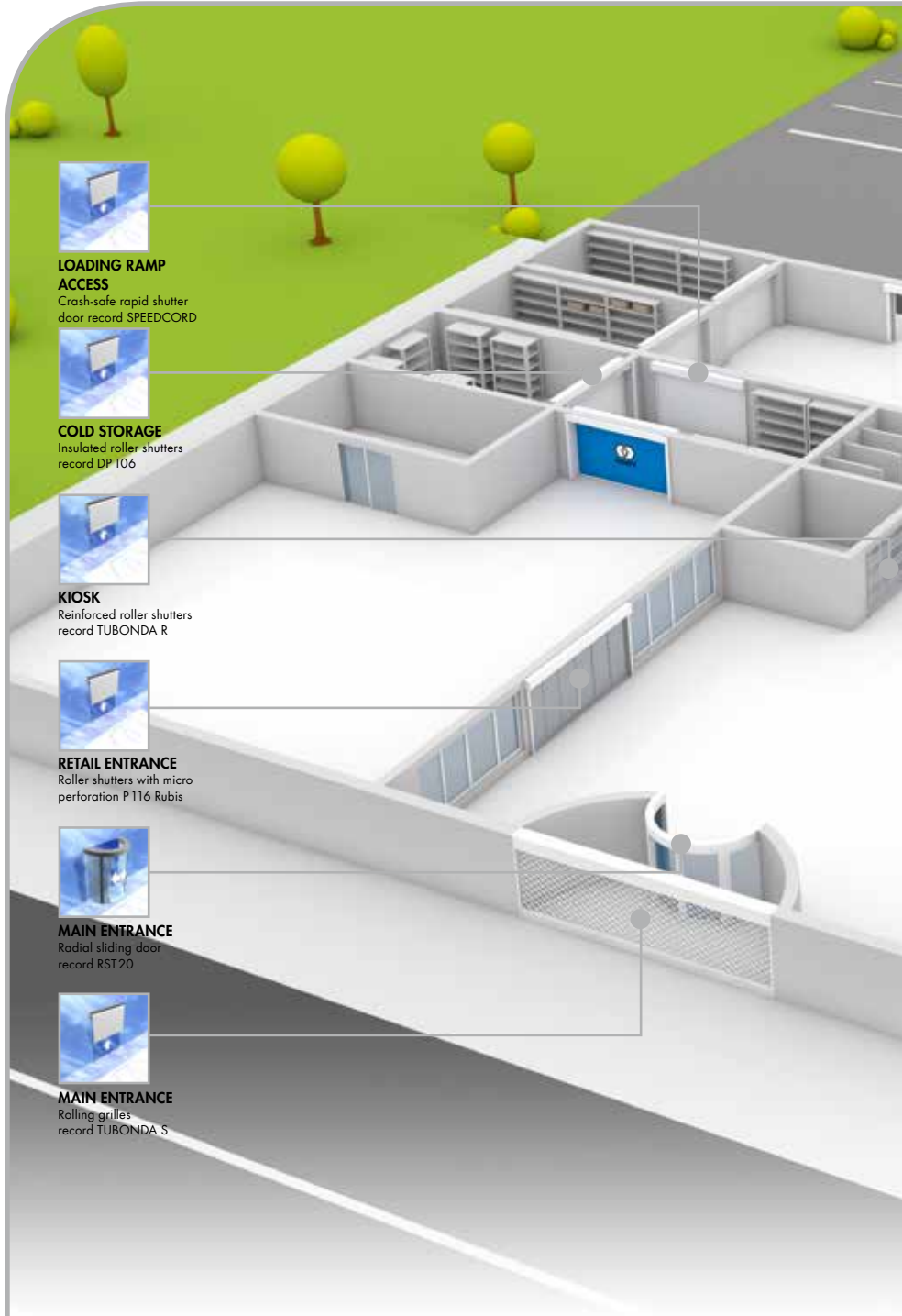

LOADING RAMP ACCESS
Crash-safe rapid shutter door record SPEEDCORD



COLD STORAGE
Insulated roller shutters record DP 106



KIOSK
Reinforced roller shutters record TUBONDA R



RETAIL ENTRANCE
Roller shutters with micro perforation P116 Rubis



MAIN ENTRANCE
Radial sliding door record RST20



MAIN ENTRANCE
Rolling grilles record TUBONDA S



Printing option NO LIMIT



Rapid shutter doors



Roller shutters



LOADING RAMP
Insulated roller shutters
record DP 106



WAREHOUSE
record GATES Miniroll



LOADING RAMP ACCESS
Printing option NO LIMIT



JEWELLERY SHOP
Roller shutters with micro perforation P 116 Rubis



SHOE SHOP
Roller shutters
record EUROLOOK



BOUTIQUE
Total opening system
record TOS



Roller shutters with partial micro perforation "Tatoo"



Roller shutters EUROLOOK



Insulated roller shutters



Full surface roller shutters

record GATES



record GATES



record

your global partner for entrance solutions

Full surface roller shutters

Their simple, robust yet flexible design, combined with their tightly rolled shutter, enables a wide range of applications: whether installed outdoors or in, the roller shutter can be adjusted to suit every situation, and are easy to integrate due to their small space requirements.

Robust steel profiles, insulated aluminum, galvanized or painted: our roller shutters always meet your requirements.

record GATES P 116 – made-to-measure protection

Maximum security at a good price for your shop or industrial location. The P 116 roller shutter is perfect for all kinds of outdoor openings. The P 116 roller shutter profile can also be ordered with perforated finish (the "Rubis" option)

record GATES P 97 – Exceptional strength

With larger sizes, the stiffness of the profile could be affected. The curved shape of the P 97 roller shutter profiles enhances not only its strength, but also enhances its smooth, quiet operation when rolling, making it perfect for commercial or industrial applications.

	record GATES P 116	record GATES P 97	record GATES P 57	record GATES DP 106
Profile	116 mm steel	97 mm steel	57 mm steel	106 mm aluminium / foam
Insulation	no	no	no	yes
Dimensions max. (W/H)	12 000 and 6 500 mm	13 500 and 12 500 mm	4 700 and 3 250 mm	8 200 and 8 000 mm
Maximum surface	70 m ²	95 m ²	12 m ²	65 m ²
Automation	yes	yes	yes	yes

record GATES P 57 – Space-saving

Ideal for shops with limited space: the profile height of only 57 mm enables the P 57 roller shutter to have a very small roller diameter. Widths available are 900 – 4700 mm; the maximum overall height is 3 250 mm.

record GATES DP 106 – with insulated hinged profiles

20 mm thick profiles ensure good insulation properties, thus reducing heat exchange with the outside.

Particularly suitable for large spaces and busy entrances, or when overhead cranes are in use.

In addition to its economic advantages, the record DP 106 roller shutter is also extremely compact and space-saving. It always delivers the right solution for overcoming cramped or narrow entrances.

Painted in anthracite grey RAL 7016, white aluminium RAL 9006 or traffic white RAL 9016 finish, it proudly becomes your new, contemporary business card, at a cost well within your budget.

For information about fitting motor drives please see the section entitled Drives and Options.



SP 130 Finishing profile



Aluminium finishing profile with profile seals



record GATES



record

your global partner for entrance solutions

record MINIROLL: automatic roller door for safe and convenient security

The record MINIROLL is an automatic roller door designed to fit windows and passage-ways, acting as effective protection against burglars and intruders. The standard design features steel slats achieving protection class RC 2 as approved by the French organization for norms and standards CNPP.

Night closing in shops

The roller door achieves high stability and rigidity thanks to the flat design of its slats, which also ensures highly compact dimensions when unextended. The rolled up curtain of doors up to 3000mm high can easily be accommodated in console covers just 250 x 250mm in size. The record MINIROLL is equally suitable for shops and private homes, and thanks to its maximum width of 4000mm, also as a navigable passage for industrial applications. The minimal dimensions of 700mm in height and 910mm in width also enable this model to provide effective security for windows.

The record anti-graffiti treatment provides effective protection against vandalism. As the door surface is treated with a protective finish, traces of felt pens, markers and spray paints can be effortlessly removed. Anti-graffiti treatment by record is officially endorsed by RATP, the Parisian transport system. It is guaranteed to withstand 50 cleaning cycles without affecting the protective finish.

Perforated or full-surface slats

Like the larger roller doors and shutters featured in the record GATES series, the record MINIROLL "Rubis" model features micro-perforated slats, enabling light and ventilation even with the door or shutter in the closed position.

Benefits

- Perfectly complements entrances and doors in shops, offices, industrial buildings and private homes
- Steel shutters available for high security protection against attempted break-ins
- Available in a range of RAL paint finishes; galvanized shutters are also available
- Easy-to-install thanks to pre-assembled drive unit
- Console can be mounted inside or outside
- Manual emergency operation mounted inside or outside door also available
- Integrated safety brake



record GATES



record

your global partner for entrance solutions

Shutter door with micro perforations (Rubis)

This shutter door is particularly suitable for show-rooms, exclusive boutiques, car dealers etc.

- Steel profiles
- Materials and finishes galvanized or painted
- Transparent effect
- Secure values

A unique roller shutter

In construction, it is simply a roller shutter with hinged profiles, but its materials (with micro perforations) make it almost a shutter door: the space behind is safe and secure, but the products being presented remain clearly visible inside, and are made incomparably more attractive to the eye!



Unique and fundamental innovation

In the world of building entrances, particularly in the field of metal blinds, we are proud to present another example of our innovative spirit: the new perforations of the P 116 profile, which do not cover its entire surface, thus enhancing its stability and reducing the risk of cracks developing.

Guaranteed visual enhancement

The TATOO option provides you with the possibility of combining the fully perforated Rubis blinds and the full surface roller shutter, enabling you to have perforations in the shape of your logo, or over just part of the curtain.



Options

The ANTI GRAFFITI and NO LIMIT options can also be selected for roller shutters with micro perforations. For further information, please see the section entitled Drives and Options.

Nylon stops on the profile ends reduce noise during operation, enabling you to dispense with the need to lubricate the guide rails.



ANTI GRAFFITI and NO LIMIT options are also available.





record GATES



record

your global partner for entrance solutions

Roller shutter record EUROLOOK®

The Standard record EUROLOOK® transparent protective roller shutter is crystal clear, with 83% transparency, allowing 92% of light to penetrate.

Thanks to its resistance to UV radiation, it does not colour or yellow, and retains its glass-like transparency year after year.

Security

The EUROLOOK® protective roller shutter consists of polycarbonate plastic links, connected at five points to ensure an optimally robust structure with a maximum of flexibility. This enables a EUROLOOK® roller shutter to yield slightly, but does not permit it to crack. This ensures a highly efficient EUROLOOK® security system.

Areas of application

For years now, EUROLOOK® protective roller shutters have been used where security and transparency are 100% necessary, i.e. in trades, shops and other businesses, as well as banks and museums.

Benefits

- Highly aesthetic system
- Ensures transparency and brightness
- Suitable for many applications

Technical Specifications

- Weight of shutter: 9 kg/m²
- Thickness of polycarbonate: 3 mm
- A maximum of 11 000mm in width and 6000mm in height

3 motor variants

- Roller motor
- Side-mounted motor
- Mid-mounted motor

For more information on motorization please see the section entitled Motorization.





SONIA
BY ZOLA STREET

DEE BY CALESI

XANESABRUDO

ISABEL MARANT

BIBIUN, BAZAAR

ANTIK-BATIK

Zepetto

n.d.c

MORICANNI-BLLO

...

23 rue

record GATES



record

your global partner for entrance solutions

Rolling grilles

In shopping centers and exhibition halls, this indispensable complement to the windows of your retail outlet covers all your security requirements.

We provide three models of rolling grilles. Whether you opt for the version with bars or the one with profiles, you always benefit from their legendary robust construction as well as our quality guarantee.

The BITUBO AR: for aesthetics, and smooth, low noise operation

Its construction from 10 x 10 mm galvanized steel profiles with connecting bars make this model ideal for large openings.

Other benefits of the BITUBO AR are its modern aesthetics and especially its smooth-running, quiet operation, thanks to its nylon end caps.

The BITUBO AR is the flagship model of our rolling grille product family; you can order it in any colour you like.

The TUBONDA S: for good looks and expert protection

The Tubonda S rolling grille consists of corrugated pipes made of galvanized steel with a diameter of 14 mm, making it ideally suited to the needs of your retail outlet. It provides maximum security for your shop window, as well as efficient protection against burglary.

The TUBONDA R for extra protection

With straight, horizontal tube reinforcements in the sections, the Tubonda R rolling grille (R means reinforced) is a direct evolution of the Tubonda S, and provides an even greater degree of strength, yet retains its elegant appearance.

3 motor variants:

- Roller motor
- Side-mounted motor
- Mid-mounted motor

For more information on motors, please see the section motorization and options.



	record BITUBO AR	record TUBONDA S	record TUBONDA R
Construction	galvanized or painted steel profiles	galvanized steel bars, corrugated	galvanized steel bars, corrugated
Diameter profile / pipes	10 / 10 mm	14 mm	14 mm
Mesh height	60 mm	110 mm	110 mm (reinforced protection)
Mesh width	243 mm	155 mm	155 mm
Dimensions max. (W/H)	13 700 und 12 500 mm	8 000 und 5 500 mm	8 000 and 5 500 mm
Maximum surface area	80 m ²	60 m ²	60 m ²

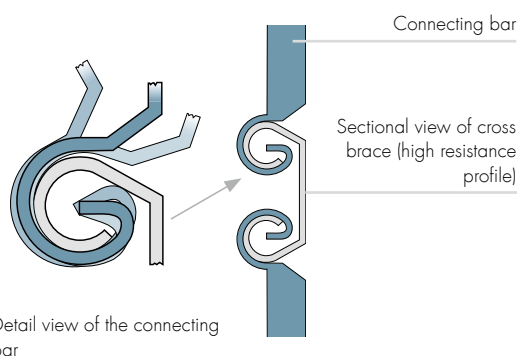

Detail view of the connecting bar

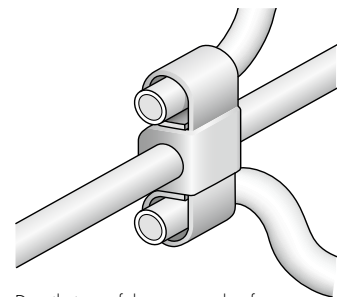

Detail view of the patented safety hinge available for TUBONDA R-type blinds





record GATES



record

your global partner for entrance solutions

record SPEEDCORD benefits: shorter opening intervals reduce heat loss

The record SPEEDCORD can be used as the connecting element between two storage areas with different temperatures. The high opening and closing speeds mean on the one hand short hold-open times, which counteract thermal exchange, and on the other, virtually eliminate possible waiting times in front of the doors. The SPEEDCORD is also very well suited as a noise barrier at the end of assembly line areas.

- Maximum size: 3000 x 3000mm
- Drive: powerful, compact and low-maintenance
- Power supply: 230VAC
- Door materials: 900g/m², choice of several colours available; print or transparent area also possible



Benefits

- All drive elements integrated into housing; no extraneous components
- User panel integrated into frame; graphic display (BDE-D)
- Power supply 230V: no external switch box required
- Warning light is maintenance-free, LED technology

Range of applications

- Supermarkets, individual shops, logistics centres, haulage and delivery companies.
- Ends of assembly lines
- Airports



The construction not only takes into consideration the stress produced by the dynamic opening and closing speeds, but also the requirements its unusual size makes on staff safety, and how it reacts to collisions.

Integrated light curtain

To enhance personal safety, therefore, a light curtain has been developed which is integrated into the sidetracks; it reaches a height of 2500mm and is equipped with additional light beams nearer the ground.



record anti-crash system (RACS)

The record anti-crash system (RACS) was developed for the SPEEDCORD to protect against damage to the shutter panel to protect against damage to the shutter panel caused by collisions from the improper handling of forklift trucks. The shutter panel is cleverly designed to slide smoothly out of its track whenever a predefined mechanical effect impacts on the SPEEDCORD.

Maintenance

The record SPEEDCORD is designed to be extremely maintenance-friendly. The brushless motor, chain drive and LED technology all contribute benefits.





record GATES



record

your global partner for entrance solutions

record sectional gates: size plus added value

The record GATES series has expanded its product range to include sectional gates suitable for industrial applications such as production halls and logistics centres. Up to 6 500 mm in height and 6 500 mm in width, they cover all the usual market requirements.

There are three models to choose from: two are 42 mm deep, the record GATES V40, with all-over steel panels, and the record GATES Panorama, featuring transparent elements. The third one, called the record GATES V80, is a sectional door featuring double-walled steel panels 80 mm deep, with particularly energy-saving benefits.

record GATES V40

Sectional doors made of steel are a rarity in the market. They have many considerable advantages and only one minor disadvantage, their weight, which for motorized doors hardly matters. The double-walled galvanized steel profile used in the record GATES V40 provides a very high degree of burglar protection compared with the aluminium model, and is generally more robust as the material used is harder. As the slats are filled with insulating foam, this model achieves a very good U-value of $0.9 \text{ W/m}^2 \text{ K}$.

record Panorama GATES

The record Panorama GATES are designed to be as transparent as possible. Fitted with crystal-clear scratch-resistant polycarbonate window panels enclosed in aluminium frames, they are available as single or double-glazed models. The segments are available in any height between 400 mm and 750 mm. A more impact-resistant model features a special SAN finish.

Elements of the Panorama can also be combined with steel panels, as in the record GATES V40 model.

record GATES V80

The record GATES V80 sectional door looks like a "mobile wall". It is the perfect solution when sound and thermal insulation are top priorities. Its 80 mm deep, foam-filled steel slats possess excellent thermal insulating qualities. The steel used not only increases the rigidity of the door, but also reduces the amount of heat exchange, resulting in an amazingly low U-value of up to $0.5 \text{ W/m}^2 \text{ K}$.

The record GATES V80 model is the right choice whenever the temperature differential between the inside and outside the door is in the region of 40 degrees Celsius.

Options

- Windows available in different sizes and models
- Hatch door possible (up to 5 000 mm wide)
- Finishes available in all RAL colours on request





record GATES



record

your global partner for entrance solutions

Innovation

We give you the option of customizing your doors and shutters with your own designs.

NO LIMIT uses Numéricoat TNM® technology for photographic quality

This is far more than just paint. By using a file of your choice, your desired enhancement data is transmitted digitally onto the surface. Full graphic freedom of expression ensures you can show off your unique selling proposition, and clearly define your commercial identity.

- Excellent resolution of photos and best print quality (600 dpi)
- Available in glossy, satin or matt finishes.
- Anti-UV treatment with a 10-year warranty; special anti-graffiti finish
- Resistant to impacts, drilling, cutting, surface treatments, detergents and bactericides
- Environmentally friendly: colour paints contain no heavy metals; polymer primer contains no solvents
- The Numéricoat TNM® process was awarded the Qualicoat® standard of quality as it complies with the most demanding standards



ANTI GRAFFITI Technology

ANTI GRAFFITI puts an end to graffiti for ever! From now on, this solution allows you to relax, secure in the knowledge that your metal blinds will not suddenly become defaced by graffiti from one day to the next.

This investment really pays off!

- The anti-defacement solution is available at a very reasonable price
- You can easily remove the traces of marker pens, permanent markers, paints and other aggressive dyes and solvents
- The protective lacquer is not adversely affected by cleaning materials of any kind

An efficient solution

The powerful anti-defacement technology has also been recognized by RATP, the Paris transport company. It is guaranteed to withstand 50 successive cleanings of all-metal blinds, sectional doors and entrance doors to residential buildings.

The anti-defacement treatment may be applied to both new and older metal blinds.



Drives and options

Drives

Four built-in solutions are available: mid-mounted motor, a roller motor, a motor with direct drive and a side-mounted motor with chain drive

Selection Criteria

- Number of cycles per day
- Frequency of use
- Area extent

Use	Mid-mounted	Roller Motor	Direct Drive	Chain
Width over 5000mm	–	•	•	•
Area over 21 m ²	–	•	•	•
over 15 cycles per day	–	–	•	•
Industrial use	–	–	•	•
Retail outlet	•	•	•	•
Voltage 380 three phase	–	–	•	•
Voltage 220 single phase	•	•	•	–
Available outside France	–	•	•	–

• available, – not available

Options

The many options we have available enable you to customize our products to your individual needs.

Storm anchors

Special guide rails and storm anchors are available for metal gates exposed to high wind.

Nylon end caps

Nylon end caps not only save the labour of lubricating the guide rails, they also significantly reduce operating noise.

Advantages of nylon cap

- Smooth, quiet operation
- Profiles are laterally rigid
- Prevents steel-steel contact

By choosing a shutter or gate from the record GATES series, you have selected the best!

Guide rails with seals

This exclusive option dampens the noise of the door during operation.

Finishing profile with seal

This innovative seal reduces the ingress of air and moisture.

Mid-mounted motor

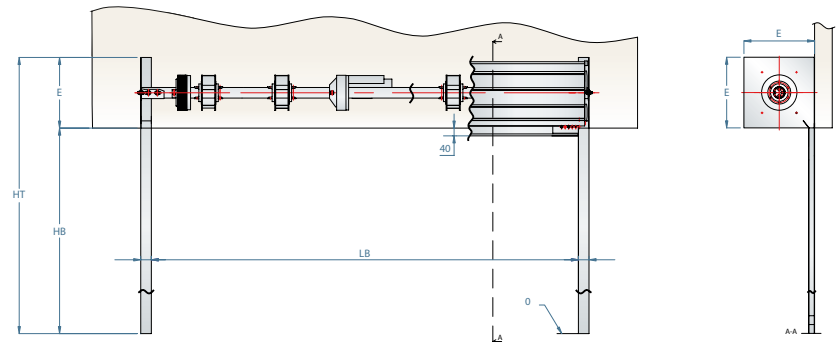

Roller motor

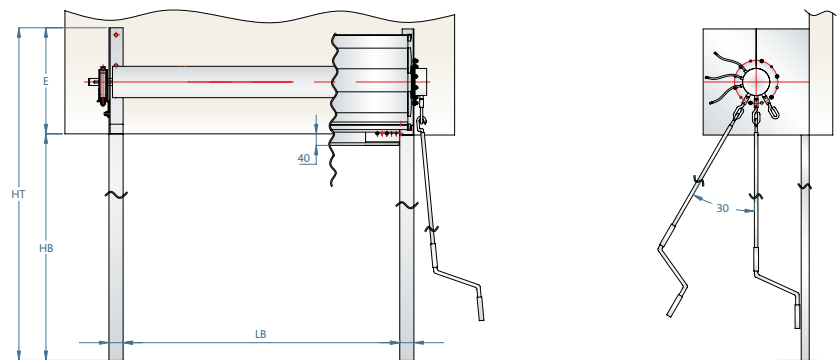

Sideways flanged motor with direct drive

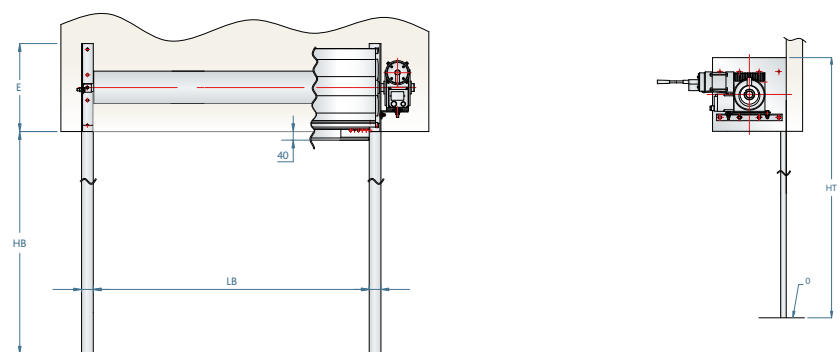

Side-mounted motor with chain drive

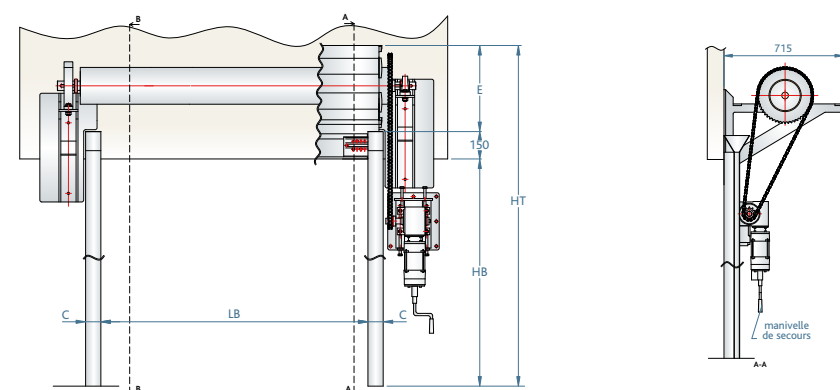

Options

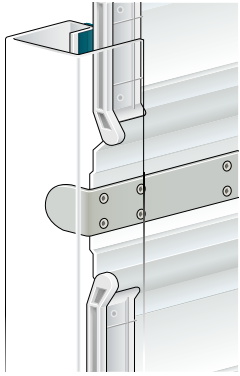

Storm anchor option

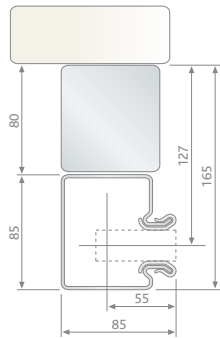

DP 106 guide rails

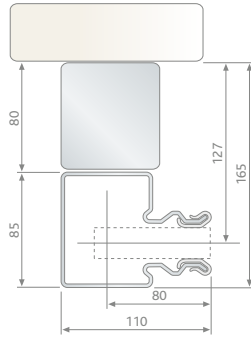

DP 106 guide rails for enhanced wind resistance



Guide rails with seal

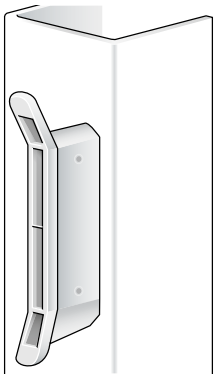

Nylon end caps option

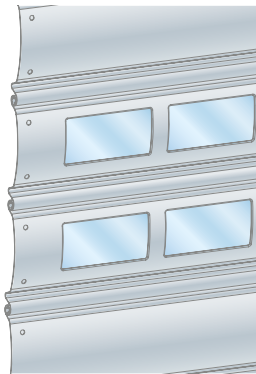

5 Inspection windows / lfm – 100x50mm

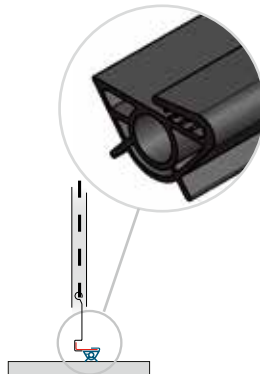

Finishing profile with seal

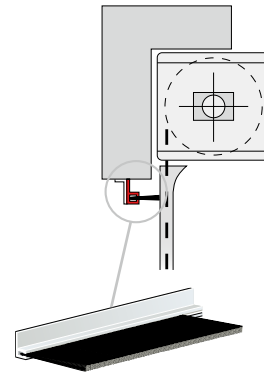

Brush seal at lintel

Options	P 97	P 116	P 57	DP 106	Rubis	TUBONDA S	TUBONDA R	BITUBO AR	SPEEDCORD
Lock with round cylinder	○	○	○	—	○	○	○	○	—
Lock with Euro-profile cylinder	○	○	○	—	○	○	○	○	—
Side locking	○	○	○	—	○	○	○	○	—
Switch type Retail outlet	○	○	○	○	○	○	○	○	—
Industry switch type 2P	○	○	○	○	○	○	○	○	—
Industry switch type 3P	○	○	○	○	○	○	○	○	—
Key-operated switch	○	○	○	○	○	○	○	○	—
Contactors Guide rails Box	○	○	○	○	○	○	○	○	—
Impact protection outside	○	○	○	○	○	○	○	○	—
Switch with impact protection outside	○	○	○	○	○	○	○	○	—
Guide rails for high winds	○	○	○	—	○	○	—	—	—
Guide rails in RAL-colours of choice	○	○	○	—	○	○	○	○	●
Blinds in RAL 9010 or 7021	○	○	—	—	○	—	—	—	—
Blinds in RAL 7016, 9006 or 9016	—	—	—	●	—	—	—	—	—
Blinds in RAL of choice	○	○	○	—	○	—	—	○	●*
Surface treatment NO LIMIT	—	○	○	—	○	—	—	—	○**
Surface treatment ANTI GRAFFITI	○	○	○	○	○	—	—	—	—
option Rubis / TATOO	—	○	—	—	—	—	—	—	—
Nylon end caps	○	○	○	○	○	—	—	●	—
Inspection window	—	○	—	—	—	—	—	—	○
Finishing profile with seal	○	○	○	●	○	○	○	○	●
Guide rails with seals	○	○	○	●	○	○	○	○	—
Brush seal at lintel	○	○	○	●	○	○	○	○	—

Key: ● Standard; ○ Option; — not available; * record SPEEDCORD blind only available in RAL 1003, 1015, 1018, 2004, 3002, 5002, 5010, 6018, 6026, 7016, 7037, 7038, 8017 and 9016; ** without surface treatment ANTI GRAFFITI

record GATES



record GATES



record

your global partner for entrance solutions

record – Inspection and Maintenance Services

We have been manufacturing and marketing automatic door systems since 1953. The very first applications were to operate doors in laundries, but automatic door drives rapidly developed into attractive entrance systems with very different functional principles, initially driven by time-saving needs. Later came the prestige element, and today our door systems enhance the architecture of any building, actively contributing to its security and safety, and saving energy by reducing heating and air conditioning costs.

In the course of these developments, our products have become increasingly more refined, their functionality more comprehensive and their operation more convenient and user-friendly. At the same time, the legal requirements have become more demanding in order to enhance operational safety.

The right service package for your needs

Today there are over 8 000 record automatic door systems installed all over Switzerland, our home market, still operating smoothly, even after 20 years or more! Our customers use them every day and this enhances their satisfaction. Reliability such as this is only possible with a combination of clear aims and goals, the highest standards of design, construction and installation, and long-term maintenance by record's highly skilled in-house service technicians.

For your automatic door to function smoothly over decades and be able to fulfil the relevant safety and security regulations, periodic servicing and maintenance is unavoidable. Benefit from the flexibility of a record maintenance contract, which will allow you to vastly reduce your operational and maintenance costs.

Your nearest record partner

Inspection and maintenance have a particularly high priority at record. The fact that record products are designed and built to last a long time also means they face changing legal requirements. To avoid unpleasant situations for our customers, we make it our priority to personalise our service and maintenance packages, enabling you to fully meet your legal requirements of due diligence.

In consultation with you, our advisor will find the ideal maintenance and service package to meet all your needs.

To know more, please get in touch with your record partner!



Contact

→ **record UK limited**

Head Office: Unit D, 9 Watt Place, Hamilton International Park – Blantyre – G72 0AH – UK

Central Office: Unit 2, Shaw Cross Court – Horace Waller V C Parade – Shaw Cross Business Park – Dewsbury – WF12 7RF – UK

Southern Office: 17 Invincible Road – Farnborough – GU14 7QU – UK

tel.: +44 1698 376411 – fax: +44 1698 376422 – info@recorduk.co.uk – www.recorduk.co.uk

→ **record global export**

agtatec ltd – Allmendstrasse 24 – 8320 Fehrltorf – Switzerland

tel.: +41 44 954 91 91 – e-mail: info@record.global – www.record.global

→ **Headquarters**

agtatec ltd – Allmendstrasse 24 – 8320 Fehrltorf – Switzerland

tel.: +41 44 954 91 91 – e-mail: info@record.group – www.record.group

